

Swichgag[®] Diagnostic Panel Kits For Cummins B and C-Series Engines

CMNS-97077B
Revised 05-08
Catalog Section 30
(00-02-0085)



W0162 and W0163

- Includes Swichgag Instruments for Critical Engine Protection
- Complete and Ready to Install
- Provision for Throttle Cable
- Fits B and C-Series Open or Closed Power Units

Description

Designed specifically for Cummins B and C-Series engines, these kits are complete with all components ready for installation.

These kits include our exclusive SWICHGAGE[®]s for basic engine protection.

A Closed-loop protective circuit is provided by Murphy 518PH magnetic switch to ensure proper operation at all times.

Features

- Unitized kit with all components
- Shock mounted panel fully assembled
- Closed-loop circuit
- Provision for additional Swichgag instruments, such as irrigation pump pressure
- Provision for tachometer and throttle cable
- Complete wiring harness allows easy installation

Dimensions (Dimensions below are for both kits)

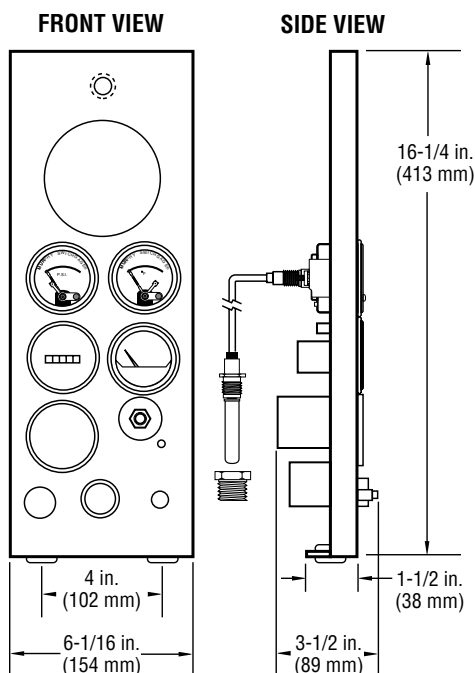

Kit Includes

- Oil pressure Swichgag instruments
- Coolant temperature Swichgag instruments
- Voltmeter
- Hourmeter
- Emergency stop push button
- Key or push button start (specify)
- Face mounted fuse
- Starter auxiliary solenoid kit (complete)
- Necessary bolts, nuts, etc. for complete kit mounting

How to Order: Order by model number.

W0162: Includes an ignition key start

W0163: Includes push button start.

(Optional) DHK: Deluxe oil pressure line assembly

Warranty

A limited warranty on materials and workmanship is given with this FW Murphy product. A copy of the warranty may be viewed or printed by going to www.fwmurphy.com/support/warranty.htm





WARNING

BEFORE BEGINNING INSTALLATION OF THIS MURPHY PRODUCT

- ✓ Disconnect all electrical power to the machine.
- ✓ Make sure the machine cannot operate during installation.
- ✓ Follow all safety warnings of the machine manufacturer.
- ✓ Read and follow all installation instructions.

INSTALLATION INSTRUCTIONS

Open Power Unit

1. Remove battery ground and secure to prevent unintentional contact.
2. Attach oil line to pressure Switchgag. Use sealant tape or pipe dope.
CAUTION: Do not allow sealant to plug pressure Switchgag orifice.
3. Feed wire harness through bottom 2 in. (51 mm) dia. hole in bracket.
4. Feed oil line through upper 2 in (51 mm) dia. hole in bracket.
5. Install panel onto mounting bracket and secure.
6. Install oil line into engine oil galley. Use sealant tape or pipe dope.
7. Install temperature sensing bulb into water jacket.
CAUTION: Be sure capillary tube is routed away from exhaust manifold.
8. Connect wire 7A to hot terminal of fuel solenoid.
9. Connect wire 8A to engine block (ground).
10. Mount starter solenoid (auxiliary magnetic switch) to bracket 30050670 and mount assembly to engine below starter.

11. Connect wire 11B to starter terminal "S".
12. Connect wires 6A, 9B, and 10B to starter terminal "Bat".
13. Connect wire 10A to either of the large terminals on starter solenoid (auxiliary magnetic switch). Connect wire 11A to other large starter solenoid terminal.
14. Connect wire 5A to either of the small terminals on the starter solenoid. Connect wire 13A to the other small terminal.
15. Connect plug (wires 1A, 4A, and 12A) to alternator.
16. Connect wire 9A and 12B to battery terminal on alternator.
17. Be sure all connections are tight and reconnect battery ground cable.
18. Service engine according to manufacturer's instructions.
19. To start engine, depress and hold red reset button on panel face (518PH magnetic switch) while cranking. Observe that oil pressure has been established and release reset button. If reset button "pops out" engine will stop. Refer to the 518PH installation operation instructions.

Closed Power Unit

1. Remove battery ground and secure to prevent unintentional contact.
2. Enlarge panel cutout on engine enclosure to fit hole pattern on panel face and expose full panel face.
3. Attach oil line to pressure Switchgag. Use sealant tape or pipe dope.
CAUTION: Do not allow sealant to plug pressure Switchgag orifice.
4. Attach Switchgag panel assembly to rear side of cutout.
5. Follow steps 7 through 19 for open power units.

Typical Wiring Diagram (all models)

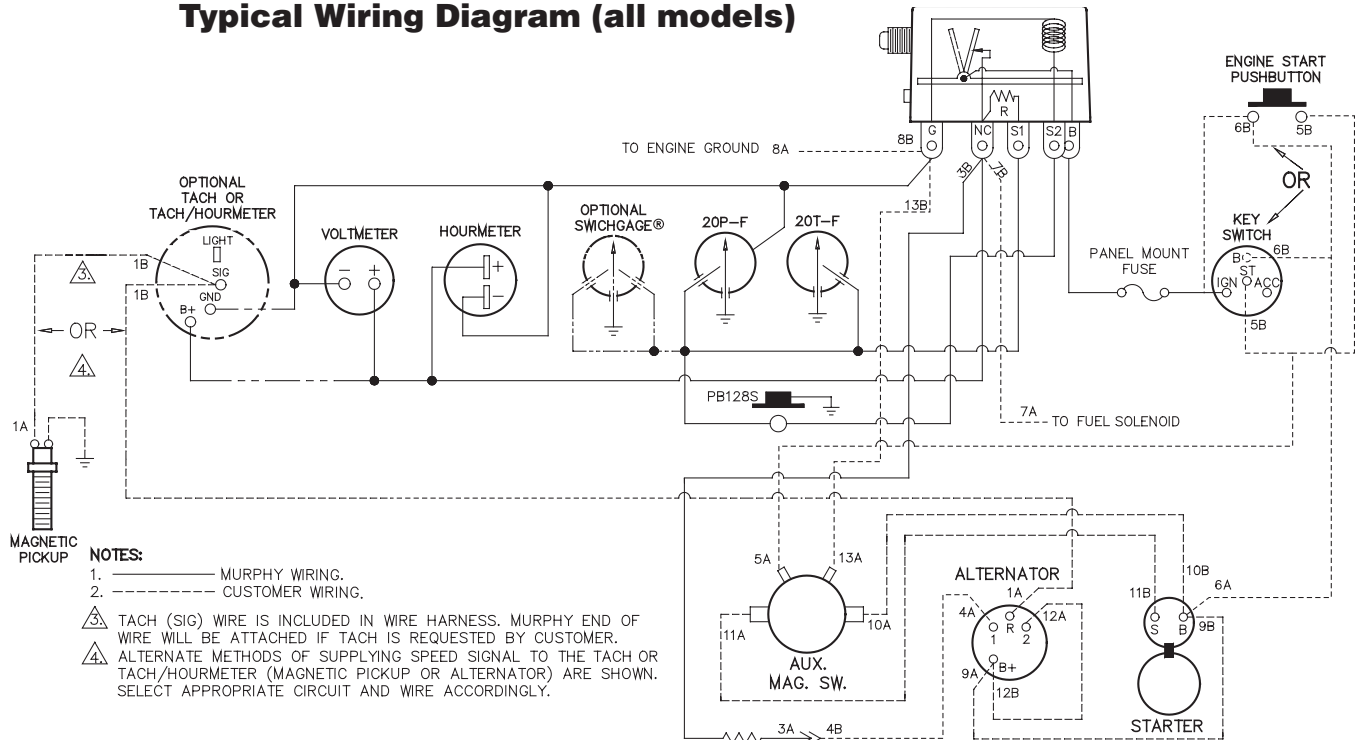

FW MURPHY

P.O. Box 470248
Tulsa, Oklahoma 74147 USA
+1 918 317 4100 Fax: +1 918 317 4266
E-mail: sales@fwmurphy.com

INDUSTRIAL PANEL DIVISION

Fax: +1 918 317 4124
E-mail: ipdsales@fwmurphy.com

MURPHY POWER IGNITION

Web site: www.murphy-pi.com

CONTROL SYSTEMS & SERVICES DIVISION

P.O. Box 1819
Rosenberg, Texas 77471 USA
Phone: +1 281 633 4500 Fax: +1 281 633 4588
E-mail: sales@fwmurphy.com

FRANK W. MURPHY, LTD

Church Rd Laverstock
Salisbury SP1 1QZ UK
Phone: +44 172 241 0055 Fax: +44 172 241 0088
E-mail: sales@fwmurphy.co.uk
Web site: www.fwmurphy.co.uk

COMPUTRONIC CONTROLS, LTD

41 - 43 Railway Terrace
Nechells, Birmingham B7 5NG UK
Phone: +44 121 327 8500 Fax: +44 121 327 8501
E-mail: sales@computroniccontrols.com
Web site: www.computroniccontrols.com

www.fwmurphy.com

FW MURPHY INSTRUMENTS (HANGZHOU) CO. LTD

77 23rd Street
Hangzhou Economic & Technological Development Area
Hangzhou, Zhejiang 310018 China
Phone: +86 571 8788 6060 Fax: +86 571 8684 8878

FW MURPHY INTERNATIONAL TRADING (SHANGHAI) CO., LTD.

Suite 17B4, Tower B, City Center of Shanghai; 100 Zunyi Road
Shanghai, 200051 China
Phone: +86 21 6237 2082 Fax: +86 21 6237 2083
Web site: mhong@fwmurphy.com



ISO 9001
REGISTERED

Printed in U.S.A.

In order to consistently bring you the highest quality, full featured products, we reserve the right to change our specifications and designs at any time.